



WHITE PAPER

CJ15ex8.5B
4K UHD Portable Lens

BUILT-IN IMAGE STABILIZATION
EMPOWERS
4K UHD PORTABLE LENS
FOR
DOCUMENTARY PRODUCTION



Written by
Larry Thorpe, Senior Fellow, Canon USA
Yotaro Sanjo, Optical Specialist, Canon USA

For more info:

pro.usa.canon.com/broadcast

© 2019 Canon USA, Inc. All rights reserved.

Contents		Page
1.0	INTRODUCTION	1
2.0	OPTICAL STABILIZATION FOR A BROADCAST TELEVISION LENS	1
3.0	PRINCIPLE OF VARI-ANGLE PRISM (VAP) OPTICAL STABILIZATION	2
4.0	CORRECTING ACTION OF THE VAP-IS STABILIZING SYSTEM	3
5.0	PRACTICAL IMPLEMENTATION OF THE VARI-ANGLE PRISM	5
6.0	TECHNOLOGIES UNDERLYING THE VARI-ANGLE PRISM	6
7.0	SUPPORTING TECHNOLOGIES FOR IMPLEMENTATION OF VAP-IS	6
8.0	CONTROL LOOP FOR THE VAP-IS SYSTEM	6
9.0	TECHNOLOGY OF THE VOICE COIL MOTOR ACTUATOR	7
10.0	MECHANICAL ACTUATORS THAT CONTROL THE VAP-IS	8
11.0	DIGITAL FEEDBACK CONTROL LOOP	9
12.0	PERFORMANCE ACHIEVED	9
13.0	SUMMARY	1

1.0 INTRODUCTION

The origination of sharp and stable imagery from a 2/3-inch 4K UHD lens-camera requires the optical image projected by the lens to remain spatially stable on the camera image sensor during exposure of that imager.

Shooting video with a handheld or shoulder-mount lens-camera system can encounter a variety of inadvertent physical perturbations that introduce image unsteadiness. This can appear in the form of a random “jiggling” or vibration of the video image viewed on a monitor resulting from inevitable human tremors when the lens-camera system is handheld. The occurrence of these can increase with protracted shooting – a consequence of normal human fatigue. Such tremors typically manifest themselves as a vibration frequency in the neighborhood of one hertz. They are compounded in amplitude, and extended in frequency, when the camera operator is walking or running while shooting. If the lens-camera is shoulder-mounted, an experienced operator can produce a quite steady image – but, over time, fatigue will invariably introduce a degree of unsteadiness. Tripod-mounted systems generally produce steady imagery – unless the system is mounted on flooring, or a tower, that is subject to vibration, or if the lens-camera system is subject to a blowing wind. Shooting hand-held while riding on a motor cycle pillion, from within an automobile, or from within aircraft or boats – all can introduce variations in vibration amplitudes and frequencies.

The basis of image stabilization is to restore the image – in real-time – to its correct spatial location on the camera image sensor system. Today, one can find three basic approaches to this: mechanical gyro-stabilized housings for the lens-camera system; electronic systems within the camera that moves sensor readout or digital sampling of the video to counter the inadvertent displacement of the optical image on the camera sensor; and optical correction within the lens itself.

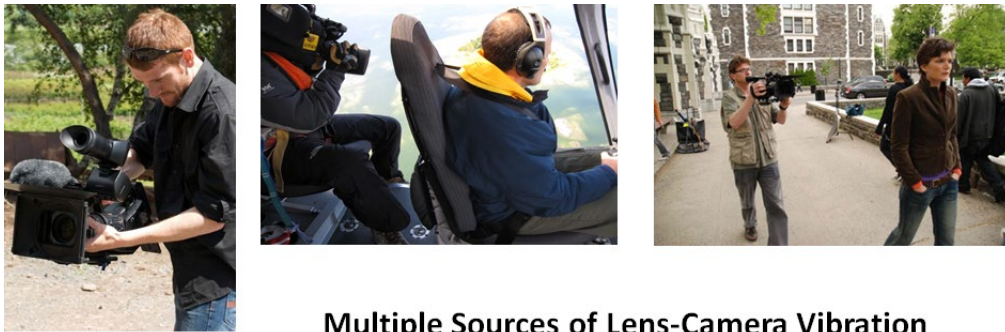

Multiple Sources of Lens-Camera Vibration



Figure 1 *Illustrating some real-world shooting scenarios that introduce video image instabilities*

2.0 OPTICAL STABILIZATION FOR A PORTABLE BROADCAST LENS

There were three motivations behind Canon’s consideration of incorporating a built-in optical stabilization system into a portable 4K UHD production lens:

- a) The very nature of 4K UHD – namely, large screen portrayal of high resolution imagery – will benefit from elimination of even a small degree of image shake that can blur that imagery
- b) The 2/3-inch image format is an internationally standardized lens-camera interface. A 2/3-inch 4K lens with built-in image stabilization will remove image unsteadiness from any associated camera regardless of manufacturer.
- c) By making the correction in the lens, both the main camera video output and the separate video portrayed in the camera viewfinder are stabilized.

Canon has pioneered two primary approaches to built-in optical stabilization in a lens. In both, special sensors detect any physical motion of the lens, and in turn, this electronic information is used to control an optical element so placed that it introduces a counter deflection to the original disturbed light rays, thereby restoring the lens output optical image to its intended spatial location on the camera image sensors. The two optical technologies are quite different and are respectively known as **Vari-Angle Prism (VAP-IS)** and **Shift-Lens (Shift-IS)** stabilization systems.

The 2/3-inch CJ15ex8.5B portable 4K UHD lens incorporates optical stabilization based upon the Vari-Angle Prism technology. This paper will describe this technology.



Figure 1 A profile shot of the new CJ15ex8.5B lens – showing the enlarged front-end barrel that houses the complete VAP-IS system – including optics, controller, and electronics.

3.0 PRINCIPLE OF VARI-ANGLE PRISM (VAP) OPTICAL STABILIZATION

The central concept underlying in-lens optical stabilization entails the placement of an optical element within the main light path of the overall lens system that has the ability to dynamically deflect in real-time light rays in a manner that counters the inadvertent deflection of those light rays because of physical disturbances and vibrations imparted to the lens-camera system. A wedge prism constitutes such an optical element. Wedge prisms come in many forms. Figure 2 shows two classic variants on a fixed wedge prism.

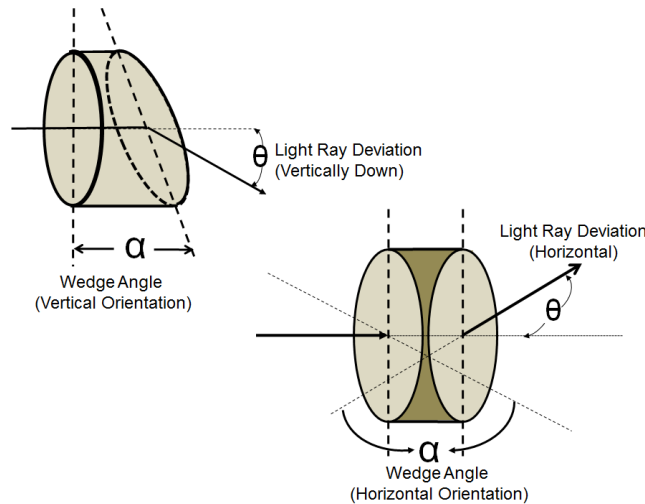

Figure 2 *Showing the optical principles of a classic fixed glass wedge prism*

A light ray passing through these glass prisms incur a deflection of amount Theta degrees, which is proportional to the wedge angle Alpha. At the top of the figure, the design is such that the entrant light ray will be deflected down by a fixed angle Theta. At the bottom of Figure 2 is shown a horizontally oriented wedge prism that will deflect the light ray in the horizontal direction.

If the angle Alpha can be made variable – in both the horizontal and vertical directions – then a dynamic control of the main light ray deflection can be implemented. Designing a wedge prism that can be adjusted both horizontally and vertically in real-time constituted the core design challenge in the development of what is termed a Vari-Angle Prism image stabilization system. Before examining details of the entailed technologies, it is useful to first understand the basic correction mechanism offered by a variable wedge prism.

4.0 CORRECTING ACTION OF THE VAP-IS STABILIZING SYSTEM

The Canon implementation of VAP-IS technology places the variable wedge prism at the optical input port of the lens system – directly in front of the focusing element group. Thus, the prism directly intercepts all of the light rays passing through the entry pupil of the lens. The manner in which the prism corrects for image shake or vibration is simply explained with reference to three sequential steps outlined in Figure 3.

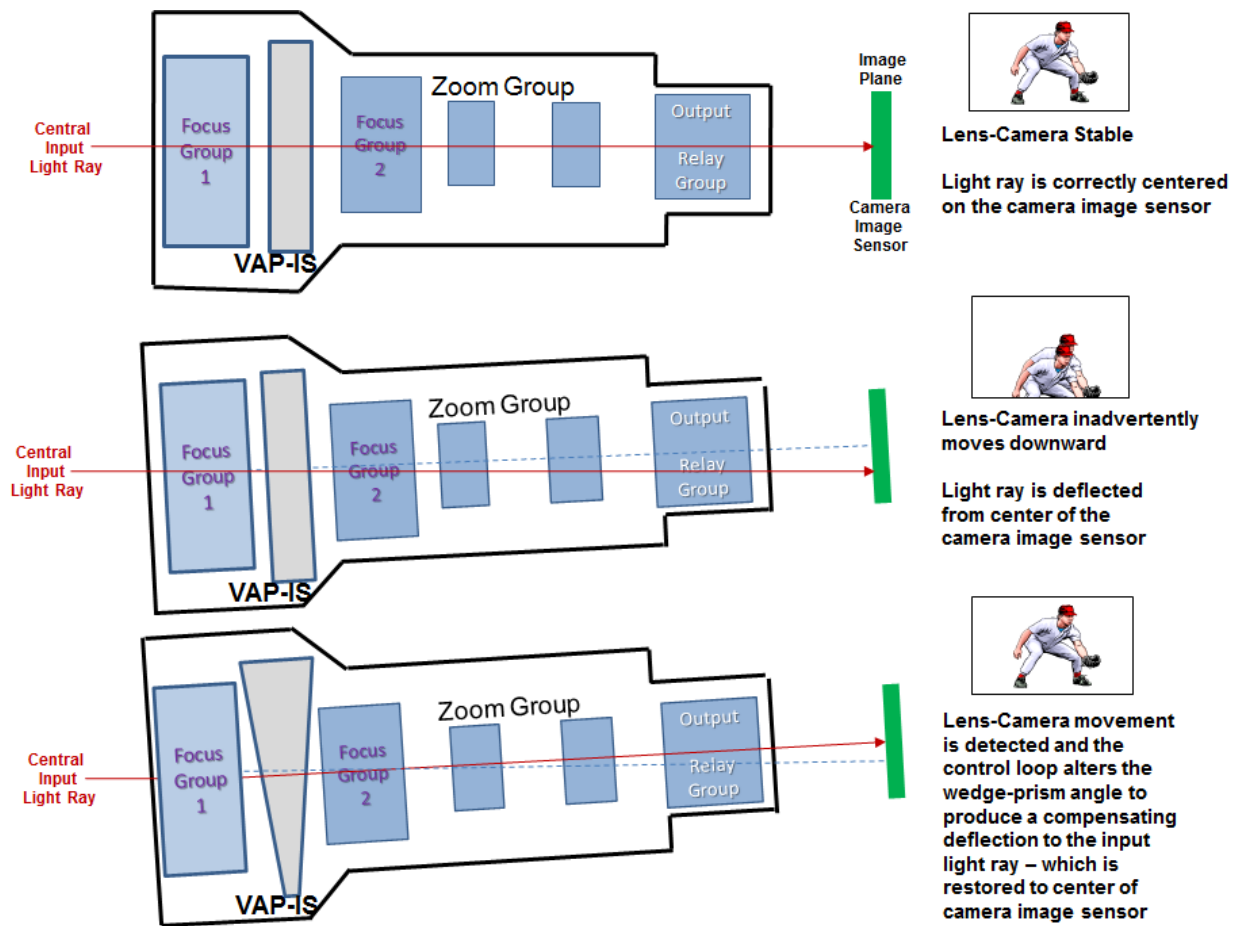

Figure 3 Outlines the sequential actions from: (a) stable lens-camera status, to (b) moment of a physical perturbation, followed by (c) the correcting counter action of the VAP-IS system

The top image illustrates conditions when the lens-camera system is stable in terms of any physical motion. The Vari-Angle Prism is in a quiescent condition and imparts zero deflection to these light rays. All of the light rays entering the lens system are focused and accurately positioned on the camera image sensor. The drawing shows the central light ray correctly positioned on the center of the imager.

The center drawing shows the momentary condition at the instant there is a physical jolt, jiggle, or vibration to the lens-camera system. Immediately, the light rays projecting from the lens are displaced on the image sensor. However, the motion detectors in the lens instantaneously signal the microcomputer that such a physical disturbance has taken place, and between them, they describe the nature of that disturbance. The microcomputer, in turn, makes high-speed calculations under control of a sophisticated algorithm and transmits a related control signal (via driver circuits) to a pair of actuators that are gripping the Vari-Angle Prism. These actuators physically “squeeze” the variable prism with high rapidity – which action implements the desired variation in the prism wedge angle that introduces the instantaneous adjustment of the angle of refraction of the light rays passing through the prism. Optical position sensors continuously sense and report to the microcomputer on the correction angle of the prism – thus closing a feedback loop that drives toward zero error.

5.0 PRACTICAL IMPLEMENTATION OF THE VARI-ANGLE PRISM

Figure 4 shows a simplified rendition of the construction of the Vari-Angle Prism. Three key attributes constitute the heart of the prism being capable of manipulation in two dimensions:

- 1) Two pieces of precisely flat circular glass joined by a flexible bellows
- 2) A high refractive index liquid that is hermetically sealed within the enclosure
- 3) The two rigid circular frames supporting the flexible bellows.

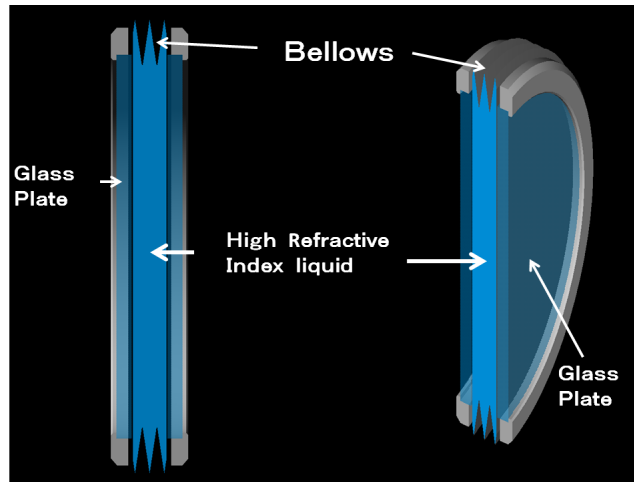

Figure 4 *Showing two views of the variable angle prism*

Two mechanical actuating systems grip the Vari-Angle Prism circular metal support, and they, in turn, are controlled by fast acting YAW and PITCH actuators. This provides the appropriate squeezing of the prism in the horizontal and vertical direction that implements the requisite prism angle – see Figure 5.

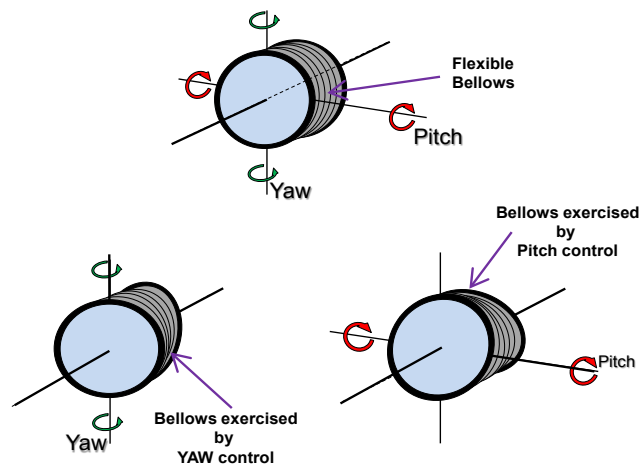

Figure 5 *At top is shown the VAP in its quiescent condition. The lower drawings illustrate the dynamics of the system – with the flexible bellows being squeezed in both H and V directions*

6.0 TECHNOLOGIES UNDERLYING THE VARI-ANGLE PRISM

A central technology is, of course, the variable angle prism itself. It took five years to perfect the first compact design of this core opto-mechanical component. This was followed by almost twenty years of ongoing refinements (driven by global field experiences) that have produced remarkable improvements to the VAP-IS system within the new CJ15 lens.

Key technologies in the Vari-Angle Prism are:

- 1) The special liquid having the requisite high-refractive index. It maintains that optical functionality over a broad lens operating temperature range of - 22 degrees F to+ 176 degrees F
- 2) Proprietary means of filling the prism with the liquid with subsequent hermetic sealing
- 3) Special multi-layer plastic material used for the prism bellows – that also sustains full operability over that temperature range, while also maintaining full pliability over the tens of millions of operational cycles anticipated over the normal life of a broadcast lens.

7.0 SUPPORTING TECHNOLOGIES FOR IMPLEMENTATION OF VAP-IS

The effectiveness of the correction is obviously dependent upon the rapidity with which this sequential process is implemented. Real-time control is the ultimate goal. A great deal of the technical development and subsequent years of continuing refinements centered about achieving this goal. Advances in motion detection sensors, a powerful new microcomputer, a more sophisticated control algorithm, and refinements to the both the controlling actuators and to the variable-angle prism itself – have collectively contributed to a more powerful stabilization system.

Specifically, three core miniature components are central to the control system:

- 1) Motion/Vibration sensors
- 2) Rotary actuators that physically manipulate the variable-angle prism are a magneto-electrical-mechanical system. They utilize miniature Voice Coil Motor (VCM) technology. These are direct drive devices based on current-carrying coil windings lying within a permanent magnetic field that produces a physical force directly proportional to the applied current. The consequent movement of the coil drives the two actuators that squeeze the prism either horizontally, vertically, or both – depending upon the microcomputer control decisions.
- 3) Microcomputer and associated specialized algorithms

8.0 CONTROL LOOP FOR THE VAP-IS SYSTEM

Figure 6 shows a simplified representation of the stabilization control loop. The Vari-Angle Prism is positioned in front of the input optical focusing group thus intercepting all of the light rays entering the lens system. This facilitates a larger correction angle.

Two motion detectors, one for horizontal movement, and a second for vertical movements, are positioned within the body of the lens. Their electronic outputs are fed to the system microcomputer – where appropriate lens motion analysis is made. The microcomputer computes a correcting control signal that feeds driver circuits that, in turn, manipulate two actuator systems that physically alter the variable wedge prism in either a horizontal, or vertical, or both directions. These actuators employ Voice Coil Motor (VCM) technology that is described below.

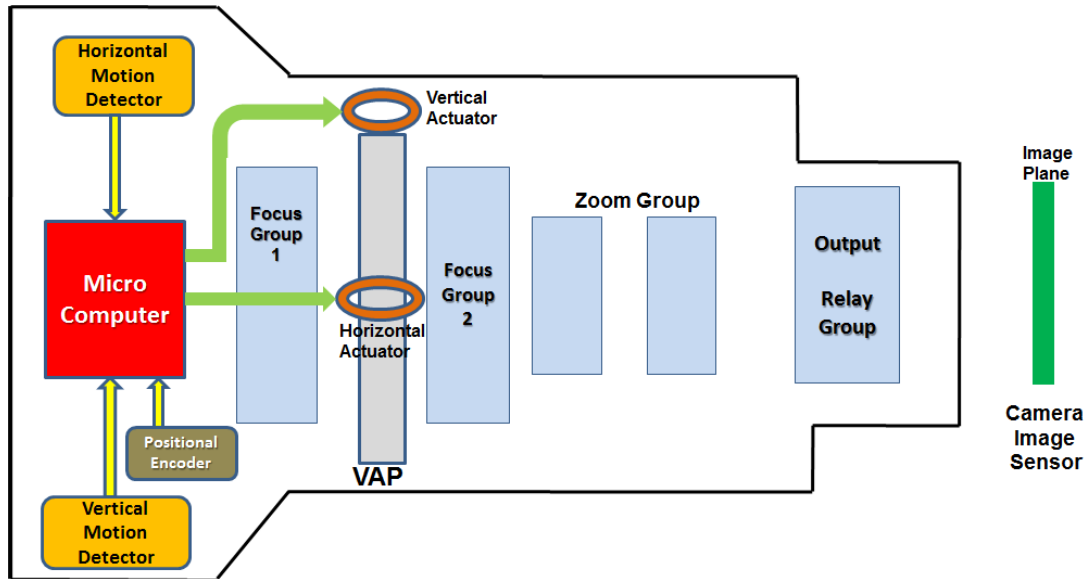

Figure 6 *Simplistic rendition of the feedback control loop that squeezes the VAP in two dimensions (H and V). The physical actuators that flex the Vari-Angle Prism are indicated by the simple coil symbol*

The prism action deflects the incoming light rays in a manner that cancels the original unwanted deflection. The position sensor that monitors the prism movement sends feedback signals to the microcomputer thus closing a feedback loop having high speed and a high degree of precision.

9.0 MECHANICAL ACTUATORS THAT CONTROL THE VAP-IS

A central part of the control loop design was development of a very fast-acting system for flexing the Variable Angle Prism. The principles of the mechanical actuators that do this are shown in Figure 7. This exploded view shows the Vari-angle Prism unit centered between the two metal supporting frames that actually grip the two metal outer rings of the prism itself. Both of the supporting frames can pivot on supporting axles. One pivots on a vertical axis (imparting a YAW or horizontal control) and the other pivots on a horizontal axis (a PITCH control).

Rotary movement of two coils that are mounted on non-magnetic armatures drives the two pivoting actions. These coils are free to move within metallic enclosures having a fixed strong permanent magnetic field. The combination of the coil and magnetic field constitute a Voice Coil Motor (VCM). If DC current fed to the “voice coil”, the coil will be physically displaced in proportion to the current.

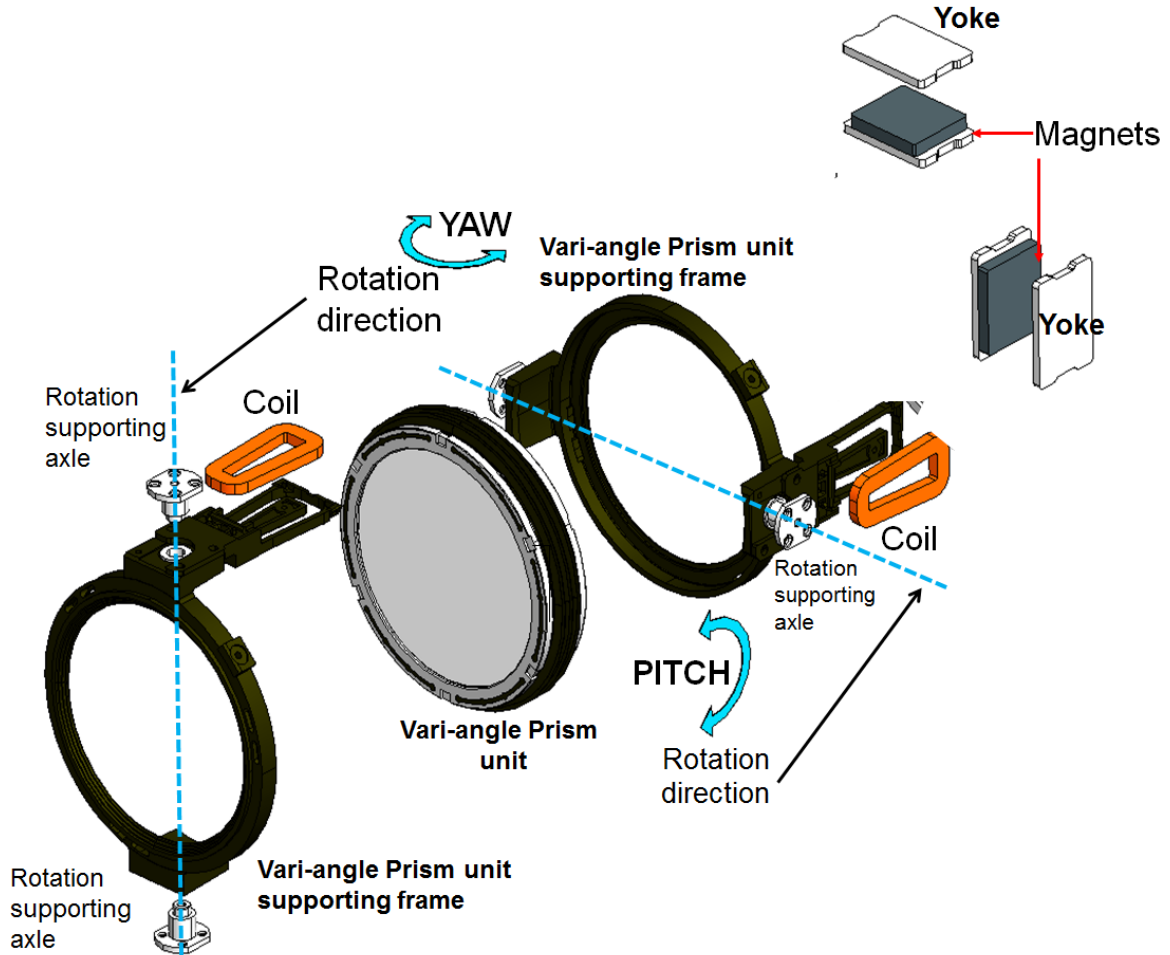

Figure 7 Showing an exploded view of the two circular mechanical support units that grip the Vari-Angle prism and apply Yaw and Pitch rotations under control of the Voice Coil Motors

Because the coil is wedge-shaped and is attached to a pivot point, its motion will be rotary. This rotary actuation imparts the pivoting controls required for the requisite “squeezing” of the Vari-Angle Prism.

10. TECHNOLOGY OF THE VOICE COIL MOTOR ACTUATOR

Extensive and continuing R&D was applied to the control system for the VAP-IS. It was considered essential that the following attributes be central to the overall performance:

- 1) Desire for as close to real-time correction – requiring an extremely fast-acting control loop

- 2) The mechanical “squeezing” of the VAP requires a high force
- 3) No overshoot or backlash when correcting for a large disturbance

Voice Coil Motor (VCM) technology has been continuously refined over many years. Today they offer excellent control characteristics when strong and precise mechanical actuation over short physical distances under electronic control is required. The VCM’s electromechanical energy conversion process is based on the *Lorentz Force* principle. This translates to a motor action that depends upon a current-carrying coil placed in a fixed magnetic field, where a strong force will act upon it, and that force is proportional to both the current and the magnetic flux density. The VCM can develop force in either direction by reversing polarity of the excitation. The coil is mounted on a non-magnetic arm and is free to move within the surrounding magnetic housing. A special wedge-shaped coil having an armature that pivots will rotate the Vari-Angle Prism supporting mechanical unit. One VCM applies YAW rotation and the second applies PITCH rotation. When the direction of the current is switched, the direction of the coil’s movement will also change. Using a coil of low inductance, this makes possible cycle times that are typically an order of magnitude faster than solenoid devices. This is essential to dealing with lens vibrational disturbances.

The key advantages of this VCM control are:

- a) Higher Force – compared to stepper or servomotor systems
- b) Higher Acceleration rates – than stepper or servomotors
- c) Direct drive – the absence of gears and cogs precludes backlash issues
- d) Zero hysteresis – advantageous when rapid change in direction is required
- e) Low acoustic noise
- f) Low heat generation – what little heat is produced is as a factor of the resistance of the coil, and a small amount due to friction

11.0 DIGITAL FEEDBACK CONTROL LOOP

When Canon developed the first broadcast standard definition portable lenses with VAP-IS in the mid-1990s they employed a sophisticated analog feedback control loop. This worked well. Over the next decade digital and microcomputer technologies advanced that facilitated the development of a far more sophisticated all-digital feedback control system for the new HC15ex8.5B high definition lens. The analog control loop that formed the first generation VAP-IS lenses has been advanced to an all-digital control system that has elevated the control loop speed twenty-fold. The basics of this digital control system are outlined in Figure 8. This digital feedback control loop achieves a twenty-fold increase in correction speed over that of its analog predecessor

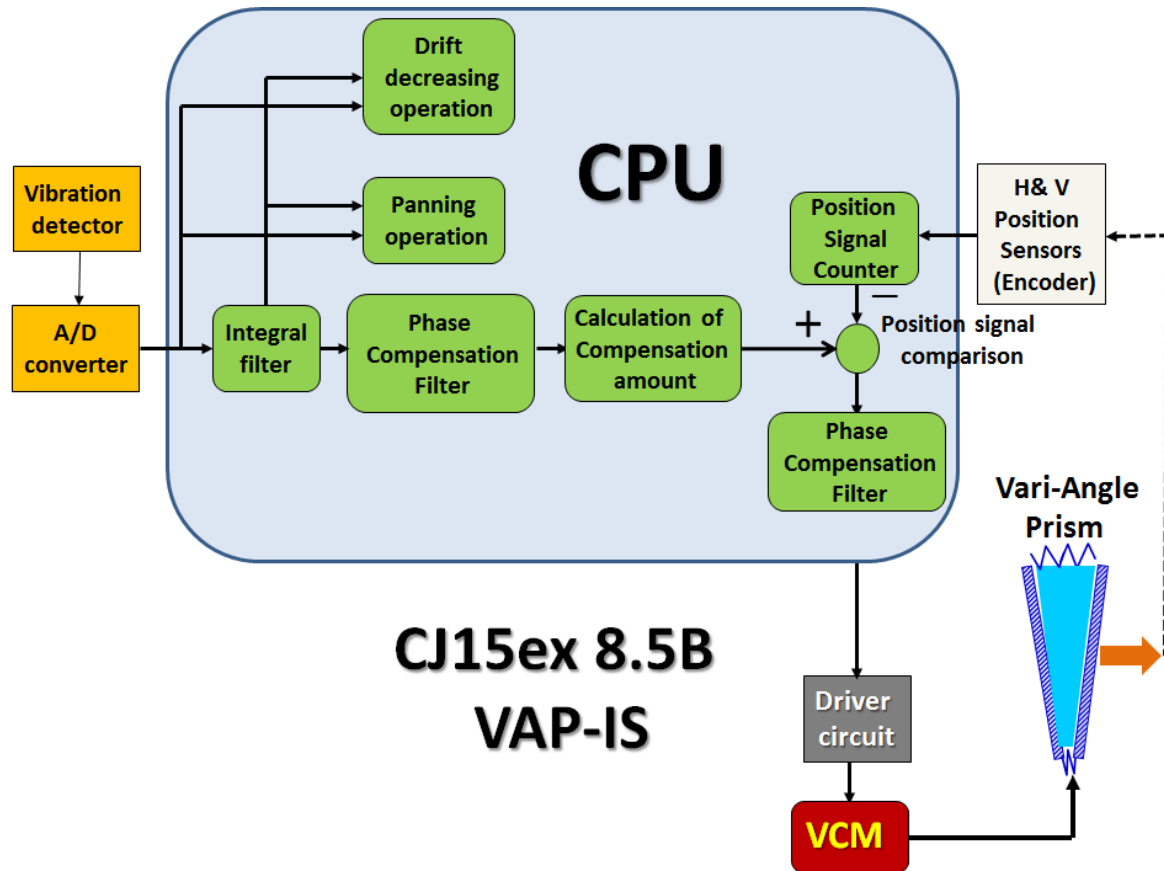

Figure 8 *A simplified block schematic of the digital control feedback loop for the VAP-IS system*

The central control algorithm includes sensing that differentiates lens-camera panning and tilting movements from physical disturbances and vibrations, and will disengage the IS correcting action during such operational moves.

The heart of the all-digital feedback control loop includes:

- (a) High-speed microcomputer that accepts, analyzes, and processes the electronic information from the motion sensors
- (b) Sophisticated control algorithm that reflects a globally accumulated operational experience with the first VAP-IS systems. This algorithm also discerns between inadvertent disturbances to the lens and operation panning and tilting of the lens
- (c) New flexible operational intervention into the correction optimization for different shooting conditions, via a matrix of four controls

12.0 PERFORMANCE ACHIEVED

Figure 9 shows the measured performance achieved within the CJ15ex8.5B portable lens. This graph assumes physical disturbances (jolts, hand tremors, or vibrations) that, uncorrected, would produce an image shift that is normalized to 100 percent. The plotted curve represents measured residual image shift following VAP-IS correction. As illustrated, over most of the frequency range, the level of correction is in the neighborhood of 100:1.

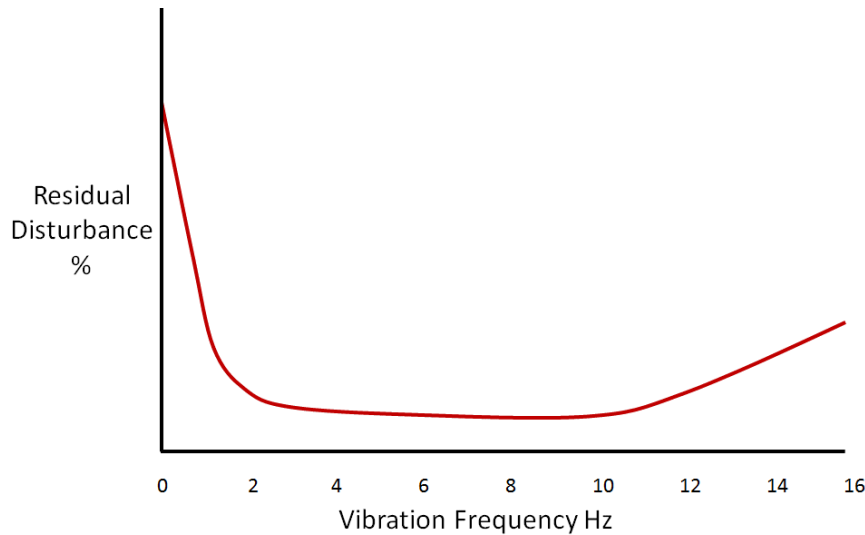

Figure 9 *Assuming a 100 percent image displacement due to physical perturbations to the lens, the curve shows the remaining percentage of image disturbance with the VAP-IS system engaged*

The frequency range shown encompasses handheld and shoulder-mount operations with the camera operator walking or running (generally in the one to four Hertz range), tripod mounted on an unstable platforms or under high-wind conditions (typically in the three to six Hertz region), and shooting from a car, motorcycle pillion seat, helicopter or boat (typically five to twelve Hertz).

13.0 SUMMARY

The CJ15ex8.5B is the world's first 4K UHD portable production lens having a built-in optical stabilization based upon Canon's patented Vari-Angle Prism Image Stabilizer technology. It is a compact lens weighing only 4.4 lbs. Advances on a number of core technological fronts have steered various refinements, producing a very fast-acting and precision control feedback loop for a novel optical stabilization technology. Measured data gleaned from a wide range of real-world shooting environments assisted development of an intelligent control algorithm that simultaneously responds to different forms of inadvertent lens disturbances and sought-for operational manipulations.

Operational adjustments, in the form of four separate stabilization modes, have been incorporated into the lens system that facilitates an increase in the degree of correction optimization for quite different shooting conditions. It is anticipated that this new lens will considerably empower the camera operator who must shoot handheld or shoulder mount over protracted time periods, or who must shoot from moving vehicles, aircraft, or boats, or operate from a tripod subject to wind or unsteady platforms.